





<p><b>Description</b></p> <p>The Power MOSFET is fabricated using the advanced planer VDMOS technology. The resulting device has low conduction resistance, superior switching performance and high avalanche energy.</p> <p><b>Features</b></p> <ul style="list-style-type: none"> <li>◆ Low <math>R_{DS(on)}</math></li> <li>◆ Low gate charge (typ. <math>Q_g = 31.4</math> nC)</li> <li>◆ 100% UIS tested</li> <li>◆ RoHS compliant</li> </ul> <p><b>Applications</b></p> <ul style="list-style-type: none"> <li>◆ Power factor correction.</li> <li>◆ Switched mode power supplies.</li> <li>◆ LED driver.</li> </ul>	<p><b>Product Summary</b></p> <table> <tr> <td><math>V_{DSS}</math></td> <td>600V</td> </tr> <tr> <td><math>I_D</math></td> <td>10A</td> </tr> <tr> <td><math>R_{DS(on),max}</math></td> <td>0.9<math>\Omega</math></td> </tr> <tr> <td><math>Q_{g,typ}</math></td> <td>31.4 nC</td> </tr> </table> <div style="display: flex; justify-content: space-around; align-items: center;"> <div style="text-align: center;">  <p>TO-262</p> </div> <div style="text-align: center;">  <p>TO-263</p> </div> <div style="text-align: center;">  <p>TO-220</p> </div> <div style="text-align: center;">  <p>TO-220F</p> </div> </div> <div style="text-align: center; margin-top: 20px;">  <p>N-Channel MOSFET</p> </div> <div style="text-align: right; margin-top: 10px;">  </div>	$V_{DSS}$	600V	$I_D$	10A	$R_{DS(on),max}$	0.9 $\Omega$	$Q_{g,typ}$	31.4 nC
$V_{DSS}$	600V								
$I_D$	10A								
$R_{DS(on),max}$	0.9 $\Omega$								
$Q_{g,typ}$	31.4 nC								

### Absolute Maximum Ratings

Parameter	Symbol	Value	Unit
Drain-Source Voltage	$V_{DSS}$	600	V
Continuous drain current ( $T_C = 25^\circ\text{C}$ ) ( $T_C = 100^\circ\text{C}$ )	$I_D$	10	A
		6.3	A
Pulsed drain current <sup>1)</sup>	$I_{DM}$	40	A
Gate-Source voltage	$V_{GSS}$	$\pm 30$	V
Avalanche energy, single pulse <sup>2)</sup>	$E_{AS}$	500	mJ
Peak diode recovery $dv/dt$ <sup>3)</sup>	$dv/dt$	5	V/ns
Power Dissipation TO-220F ( $T_C = 25^\circ\text{C}$ ) Derate above $25^\circ\text{C}$	$P_D$	40	W
		0.32	W/ $^\circ\text{C}$
Power Dissipation TO-220\ TO-262\ TO-263 ( $T_C = 25^\circ\text{C}$ ) Derate above $25^\circ\text{C}$	$P_D$	130	W
		1.04	W/ $^\circ\text{C}$
Operating junction and storage temperature range	$T_J, T_{STG}$	-55 to +150	$^\circ\text{C}$
Continuous diode forward current	$I_S$	10	A
Diode pulse current	$I_{S,pulse}$	40	A

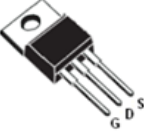
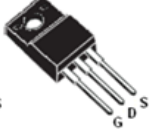
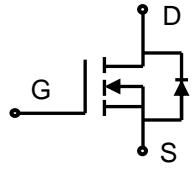
### Thermal Characteristics

Parameter	Symbol	Value		Unit
		TO-220F	TO-220\TO-251\TO-252	
Thermal resistance, Junction-to-case	$R_{\theta JC}$	3.13	0.96	$^\circ\text{C}/\text{W}$
Thermal resistance, Junction-to-ambient	$R_{\theta JA}$	110	62.5	$^\circ\text{C}/\text{W}$

### Electrical Characteristics T<sub>c</sub> = 25°C unless otherwise noted

Parameter	Symbol	Test Condition	Min.	Typ.	Max.	Unit
<b>Static characteristics</b>						
Drain-source breakdown voltage	BV <sub>DSS</sub>	V <sub>GS</sub> =0 V, I <sub>D</sub> =0.25 mA	600	-	-	V
Gate threshold voltage	V <sub>GS(th)</sub>	V <sub>DS</sub> =V <sub>GS</sub> , I <sub>D</sub> =0.25 mA	2	-	4	V
Drain cut-off current	I <sub>DSS</sub>	V <sub>DS</sub> =600 V, V <sub>GS</sub> =0 V, T <sub>j</sub> = 25°C T <sub>j</sub> = 125°C	-	-	1 100	μA
Gate leakage current, Forward	I <sub>GSSF</sub>	V <sub>GS</sub> =30 V, V <sub>DS</sub> =0 V	-	-	100	nA
Gate leakage current, Reverse	I <sub>GSSR</sub>	V <sub>GS</sub> =-30 V, V <sub>DS</sub> =0 V	-	-	-100	nA
Drain-source on-state resistance	R <sub>DS(on)</sub>	V <sub>GS</sub> =10 V, I <sub>D</sub> =5A	-	0.65	0.9	Ω
<b>Dynamic characteristics</b>						
Input capacitance	C <sub>iss</sub>	V <sub>DS</sub> = 25 V, V <sub>GS</sub> = 0 V, f = 1 MHz	-	1620	-	pF
Output capacitance	C <sub>oss</sub>		-	138.2	-	
Reverse transfer capacitance	C <sub>rss</sub>		-	6.6	-	
Turn-on delay time	t <sub>d(on)</sub>	V <sub>DD</sub> = 300 V, I <sub>D</sub> = 10 A R <sub>G</sub> = 10 Ω, V <sub>GS</sub> =15 V	-	15	-	ns
Rise time	t <sub>r</sub>		-	32.6	-	
Turn-off delay time	t <sub>d(off)</sub>		-	61.6	-	
Fall time	t <sub>f</sub>		-	14.5	-	
<b>Gate charge characteristics</b>						
Gate to source charge	Q <sub>gs</sub>	V <sub>DD</sub> =480 V, I <sub>D</sub> =10 A, V <sub>GS</sub> =0 to 10 V	-	8.3	-	nC
Gate to drain charge	Q <sub>gd</sub>		-	10.2	-	
Gate charge total	Q <sub>g</sub>		-	31.4	-	
Gate plateau voltage	V <sub>plateau</sub>		-	5	-	V
<b>Reverse diode characteristics</b>						
Diode forward voltage	V <sub>SD</sub>	V <sub>GS</sub> =0 V, I <sub>F</sub> =10 A	-	-	1.5	V
Reverse recovery time	t <sub>rr</sub>	V <sub>R</sub> =300 V, I <sub>F</sub> =10 A, di <sub>F</sub> /dt=100 A/μs	-	370	-	ns
Reverse recovery charge	Q <sub>rr</sub>		-	3.14	-	μC
Peak reverse recovery current	I <sub>rrm</sub>		-	17	-	A

**Notes:**

- Pulse width limited by maximum junction temperature.
- L=10mH, I<sub>AS</sub> = 10A, Starting T<sub>j</sub>= 25°C.
- I<sub>SD</sub> = 10A, di/dt ≤ 100A/μs, V<sub>DD</sub> ≤ BV<sub>DSS</sub>, Starting T<sub>j</sub>= 25°C.

### Electrical Characteristics Diagrams

Figure 1. Typical Output Characteristics

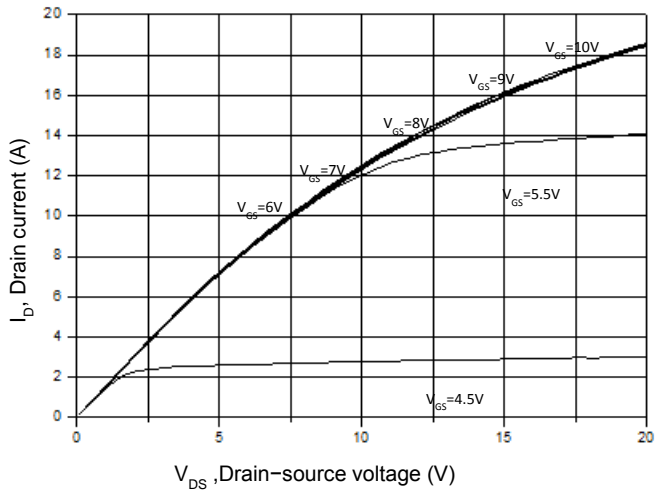

Figure 2. Transfer Characteristics

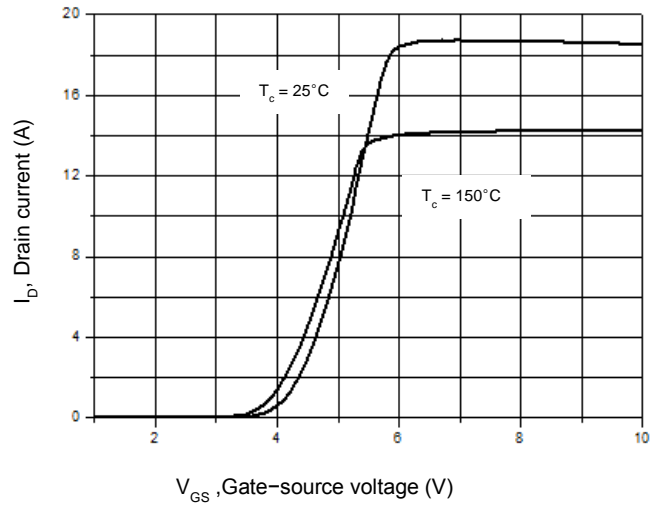

Figure 3. On-Resistance Variation vs. Drain Current

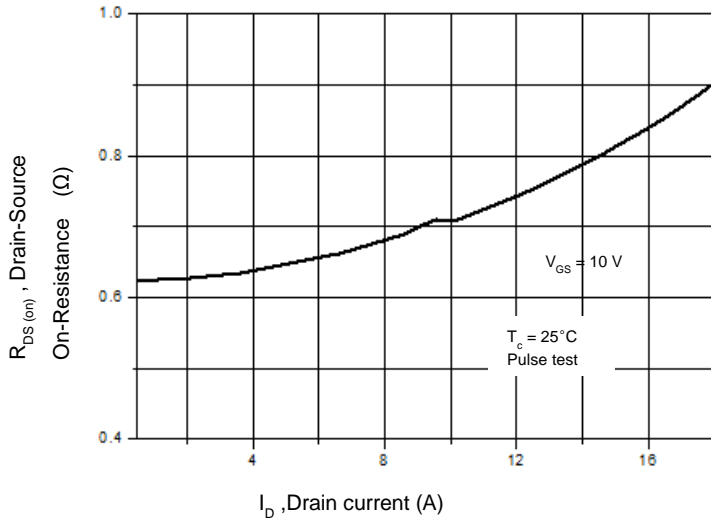

Figure 4. Threshold Voltage vs. Temperature

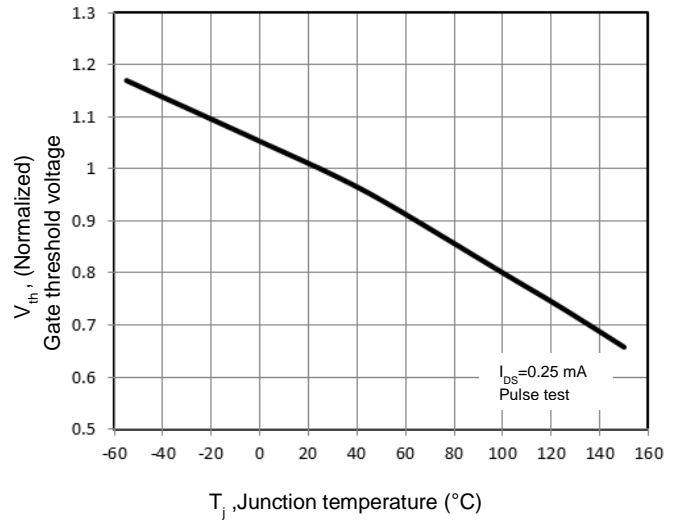

Figure 5. Breakdown Voltage vs. Temperature

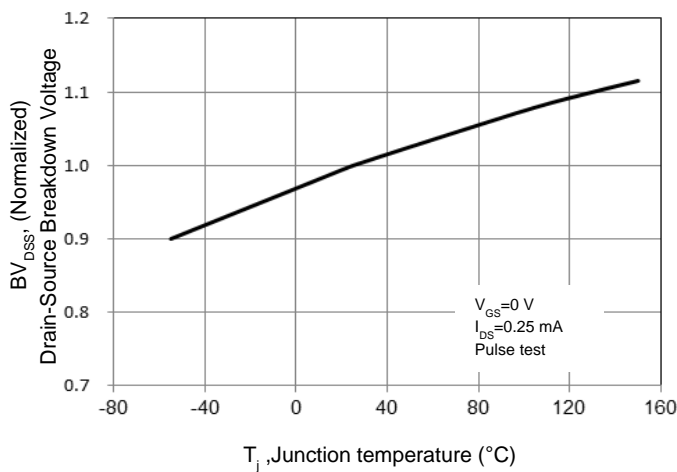

Figure 6. On-Resistance vs. Temperature

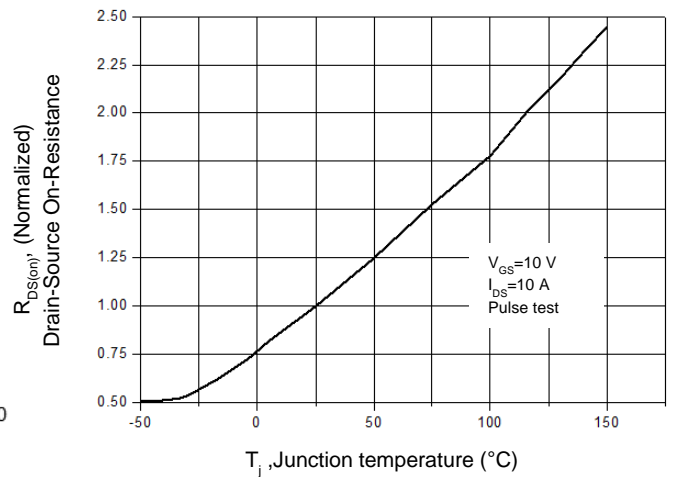

Figure 7. Capacitance Characteristics

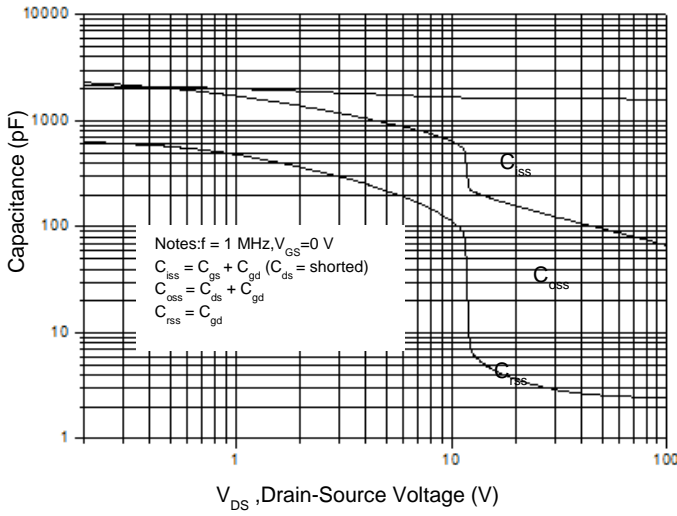

Figure 8. Gate Charge Characterist

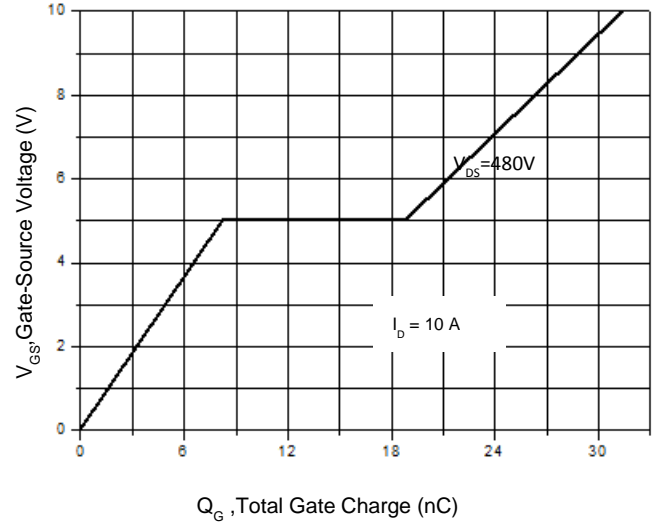

Figure 9. Maximum Safe Operating Area  
TO-220F

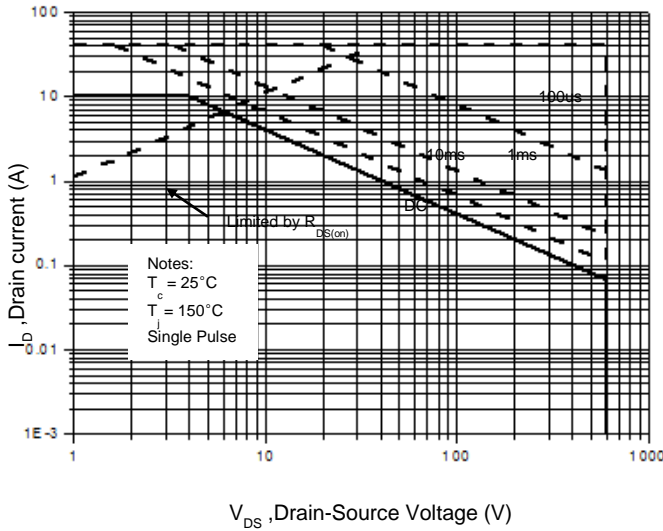

Figure 10. Maximum Safe Operating Area  
TO-220/ TO-262/TO-263

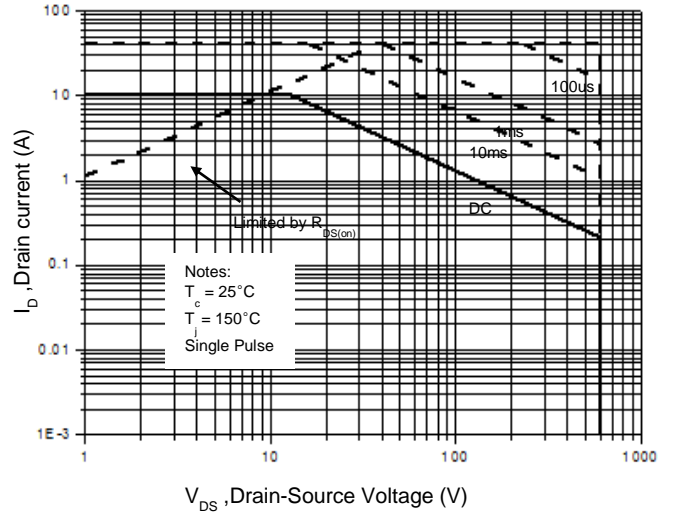

Figure 11. Power Dissipation vs. Temperature  
TO-220F

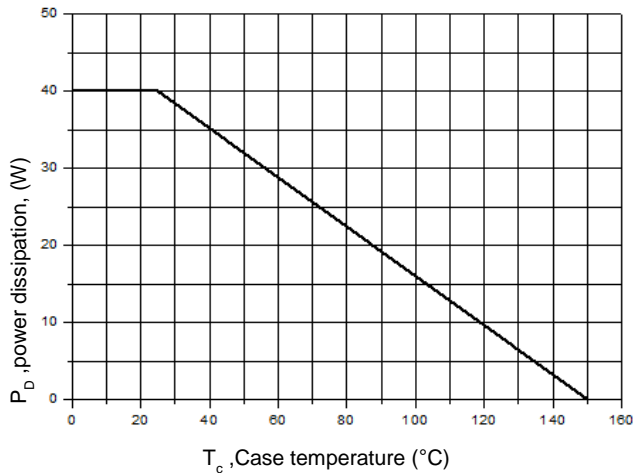

Figure 12. Power Dissipation vs. Temperature  
TO-220/ TO-262/TO-263

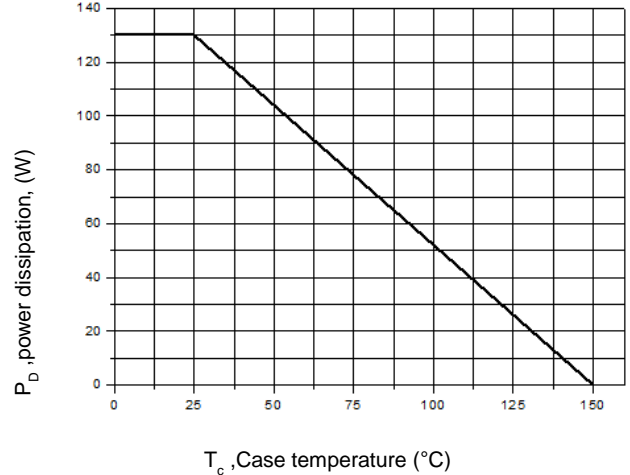

Figure 13. Continuous Drain Current vs. Temperature

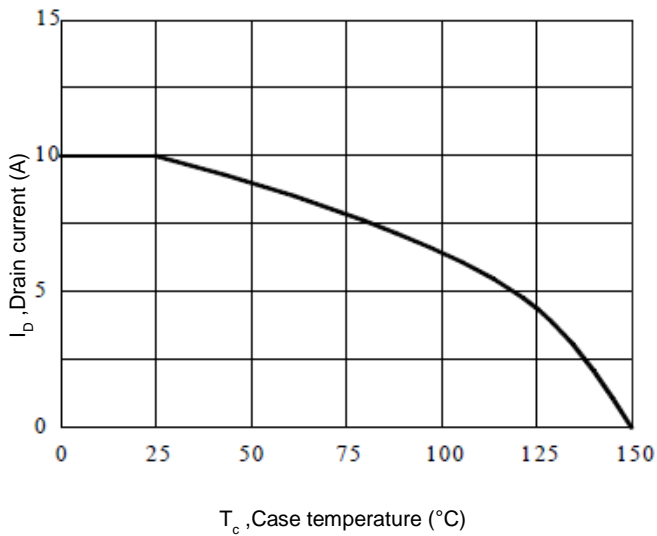

Figure 14. Body Diode Transfer Characteristics

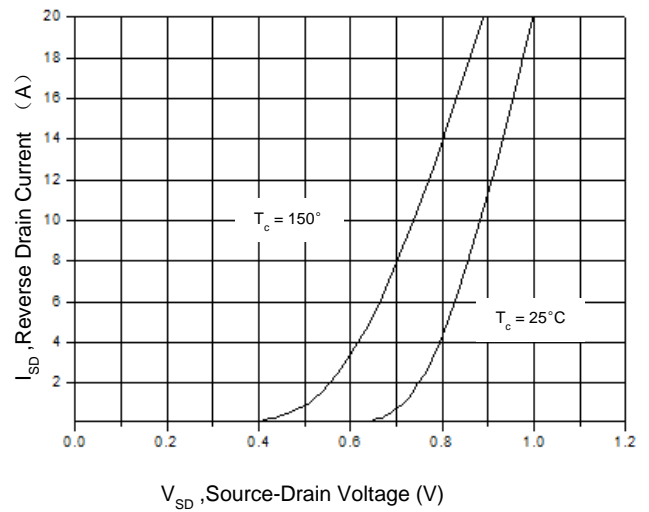

Figure 15 Transient Thermal Impedance, Junction to Case, TO-220F

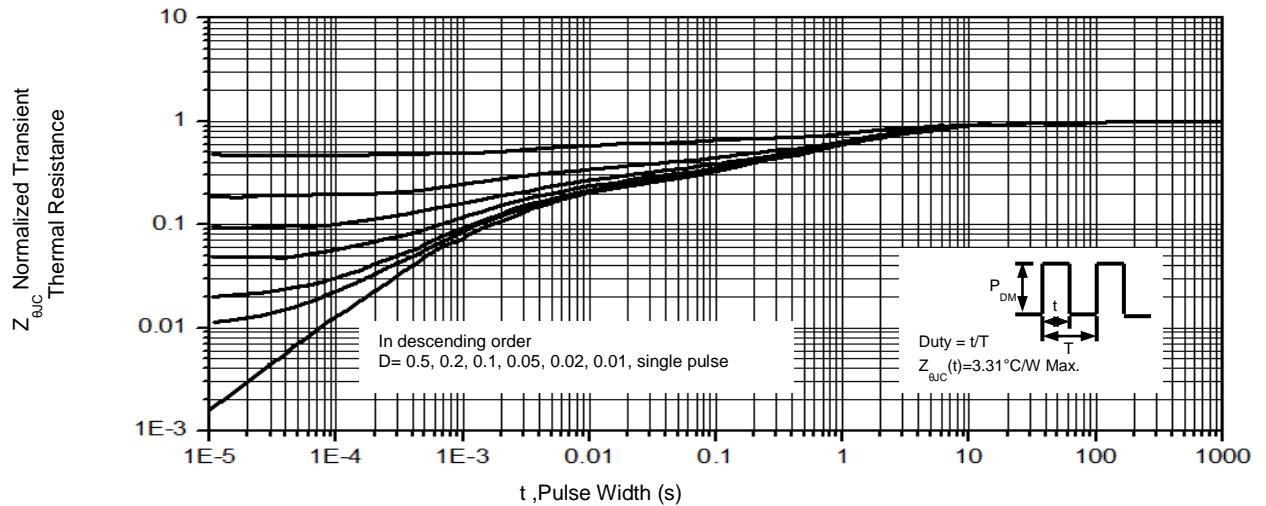
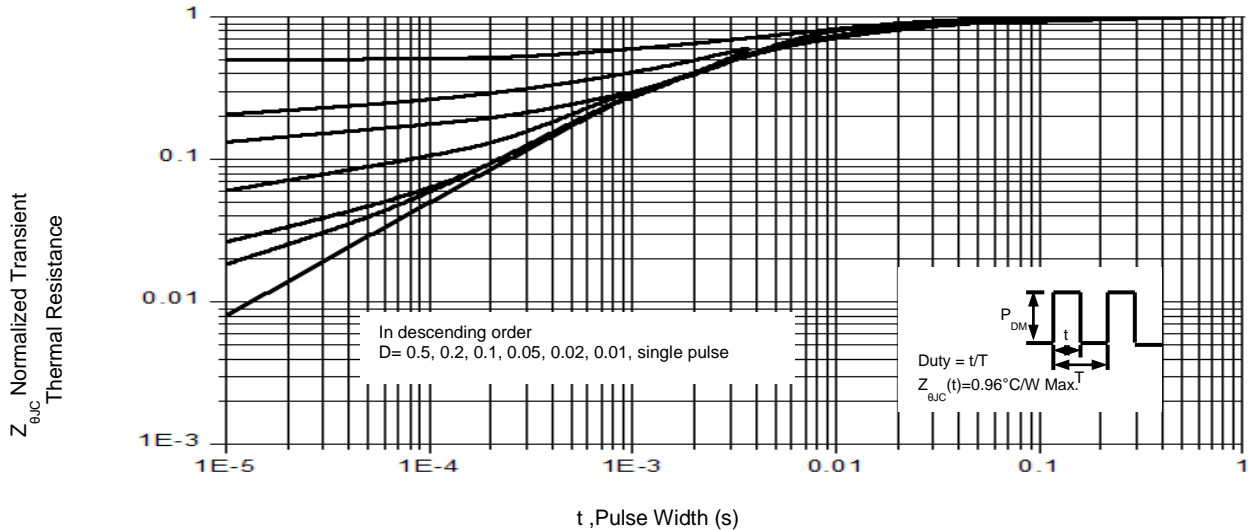
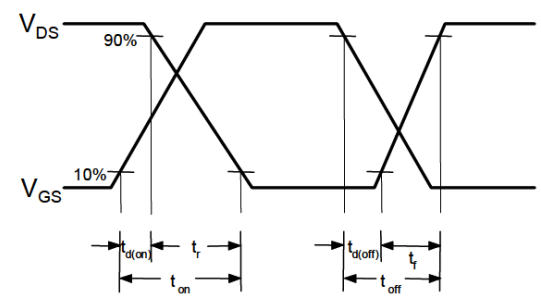
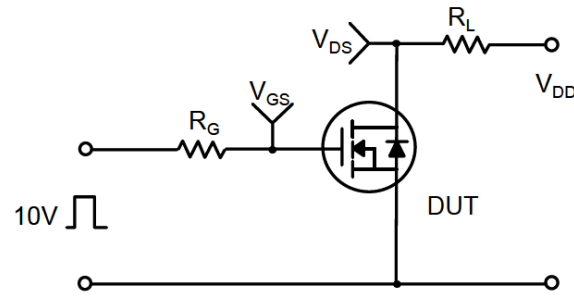
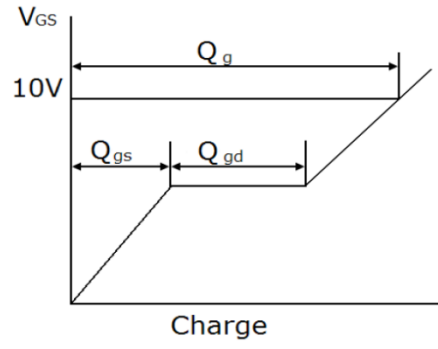
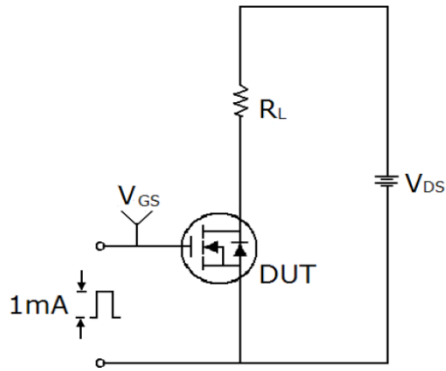

Figure 16. Transient Thermal Impedance, Junction to Case, TO-220/ TO-262/ TO-263



### Gate Charge Test Circuit & Waveform



### Unclamped Inductive Switching Test Circuit & Waveforms

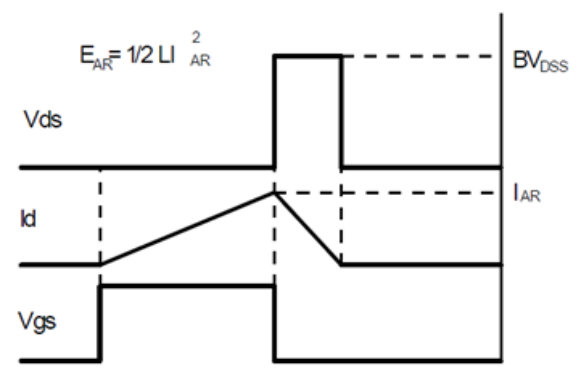
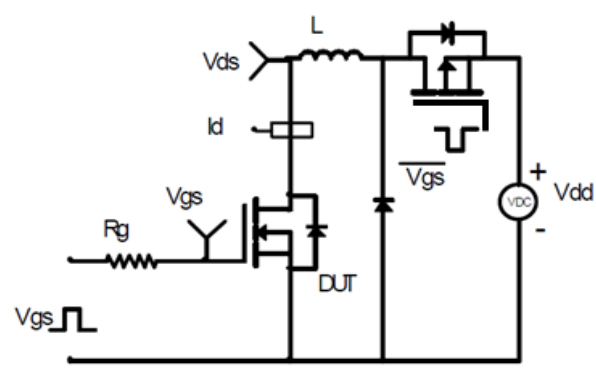

### Mechanical Dimensions for TO-220

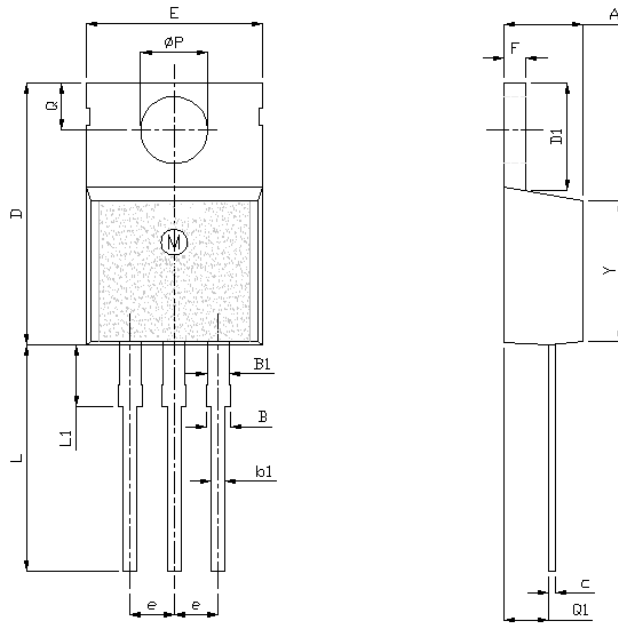

UNIT: mm

SYMBOL	MIN	NOM	MAX
A	4		4.8
B	1.2		1.4
B1	1		1.4
b1	0.75		0.95
c	0.4		0.55
D	15		16.5
D1	5.9		6.9
E	9.9		10.7
e	2.44	2.54	2.64
F	1.1		1.4
L	12.5		14.5
L1	3	3.5	4
ΦP	3.7	3.8	3.9
Q	2.5		3
Q1	2		2.9
Y	8.02	8.12	8.22

### TO-220 Part Marking Information

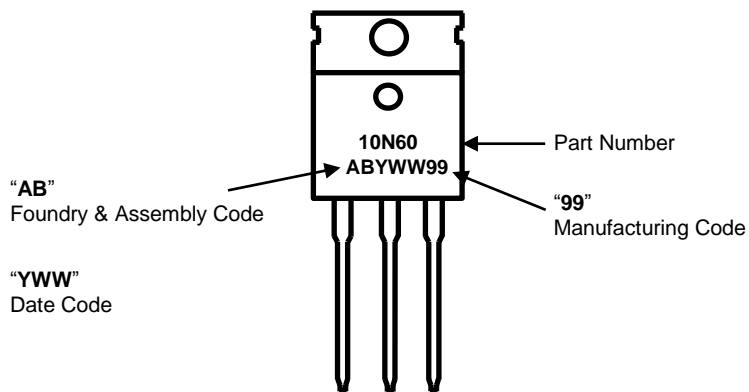

### Mechanical Dimensions for TO-220F

UNIT: mm

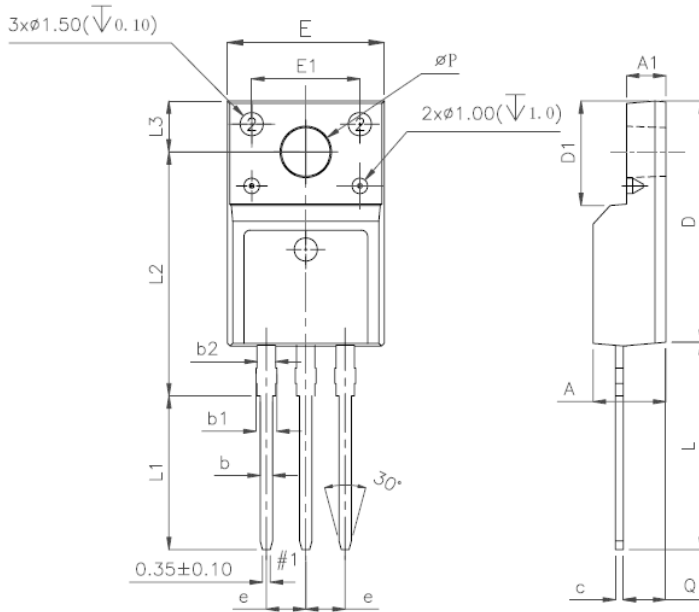

SYMBOL	MIN	NOM	MAX
A	4.5		4.9
A1	2.3		2.9
b	0.65		0.9
b1	1.1		1.7
b2	1.2		1.4
c	0.35		0.65
D	14.5		16.5
D1	6.1		6.9
E	9.6		10.3
E1	6.5	7	7.5
e	2.44	2.54	2.64
L	12.5		14.3
L1	9.45		10.05
L2	15		16
L3	3.2		4.4
φP	3		3.3
Q	2.5		2.9

### TO-220F Part Marking Information

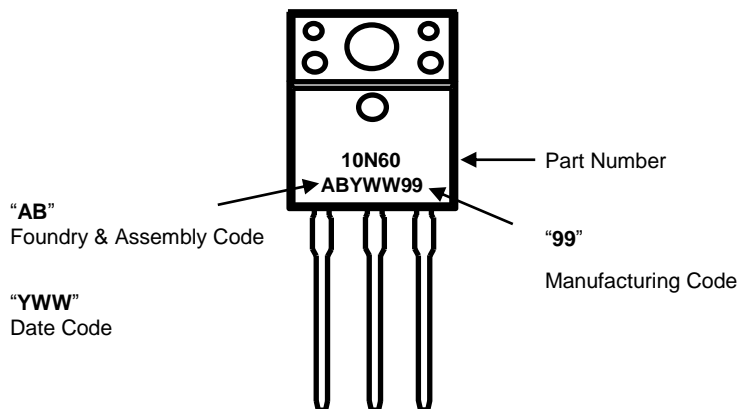

## Mechanical Dimensions for TO-262

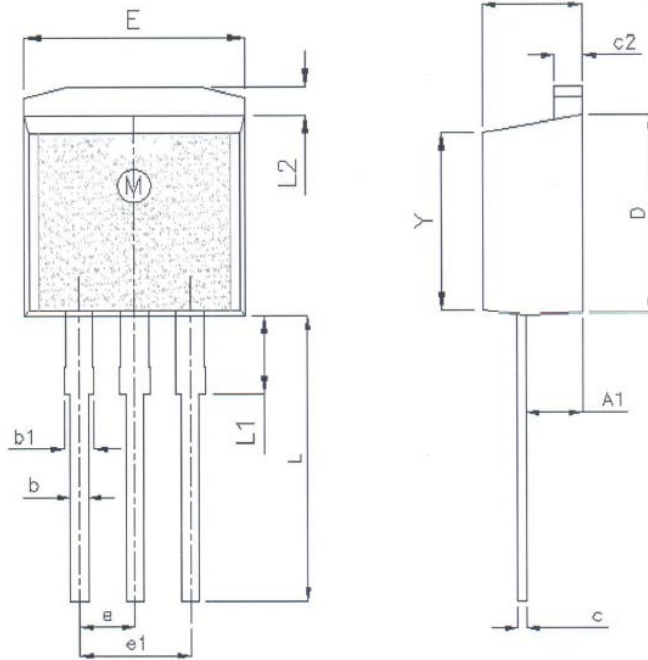

UNIT: mm

SYMBOL	MIN	NOM	MAX
A	4.42		4.72
A1	2.40		2.80
b	0.76		0.86
b1	1.22		1.40
c	0.33		0.43
c2	1.22		1.35
D	8.99		9.29
e	2.44	2.54	2.64
e1	4.98		5.18
E	9.95		10.25
L	12.50		13.60
L1	3.30	3.50	3.80
L2	1.22		1.40
Y	8.02	8.12	8.22

## TO-262 Part Marking Information

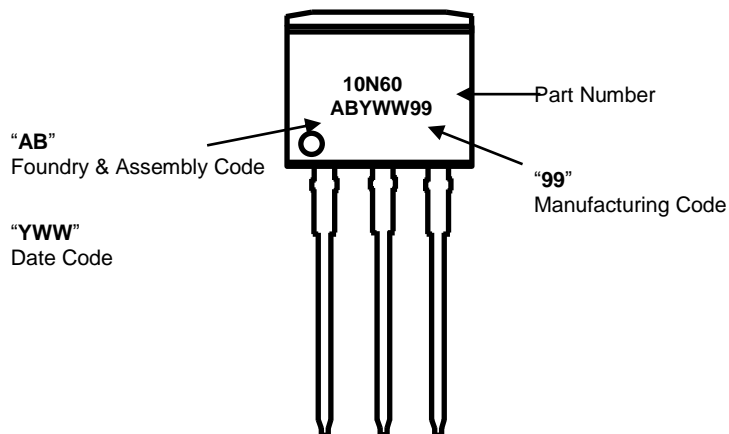

## Mechanical Dimensions for TO-263

UNIT: mm

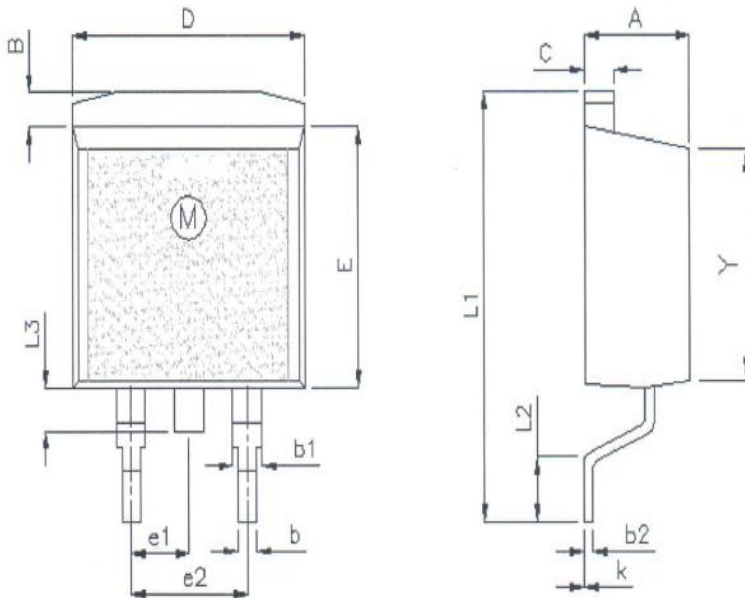

SYMBOL	MIN	NOM	MAX
A	4.42		4.72
B	1.22		1.4
b	0.76		0.86
b1	1.22		1.4
b2	0.33		0.43
C	1.22		1.35
D	9.95		10.25
E	8.99		9.29
e1	2.44	2.54	2.64
e2	4.98		5.18
L1	14.7	15.1	15.5
L2	2	2.3	2.6
L3	1.5		2
K	-0.1		0.1
Y	8.02	8.12	8.22

## TO-263 Part Marking Information

